

5

4

3

2

1



D

C

B

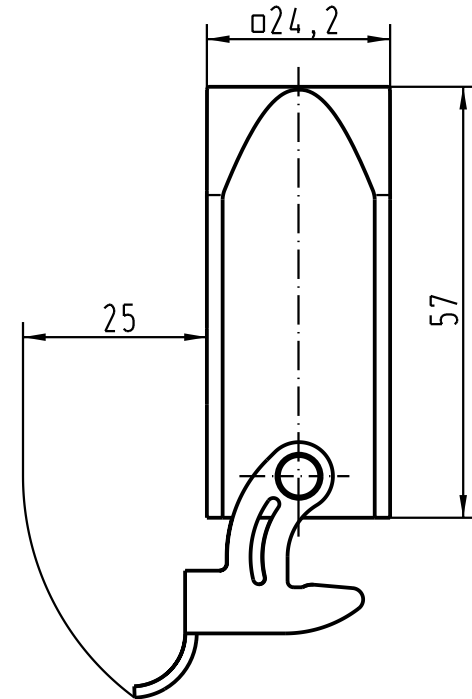
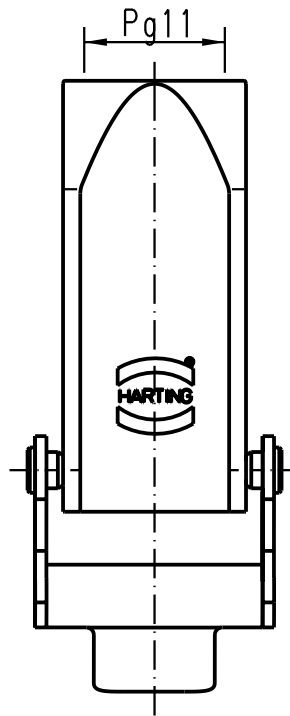
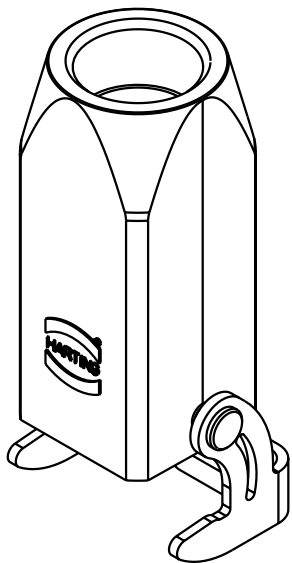
A

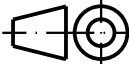

 All Dimensions in mm Original Size DIN A 4			Techn. Character.			Nicht tolerierte Masse/ Free size tolerances		
				Dat.	Name	Maststab/ Scale		
			Detail.	04.02.93	MEIER	1 : 1		
			Insp.		SDT			
			Stand.					
30196	09.11.01	DY	HARTING Electric GmbH & Co. KG			TB 09 20 003 1750 Sub. f. TB 09 20 003 1750 v.24.02.92		
25629	16.04.99	PL	D-32339 Espelkamp					
Mod.	Dat.	Name				Blatt/ page		